

POMPE A TRASCINAMENTO MAGNETICO

MAGNETIC DRIVE PUMPS

SERIE MAG



 Pompe a trascinamento magnetico per il trasferimento di acidi, liquidi corrosivi, solventi per la stampa fotografica, liquidi alcalini, acqua salata, ecc.

Corpo pompa e girante in propilene con fibre di vetro. Albero in ceramica. La girante incorpora un magnete. Il magnete di comando dall'esterno del corpo pompa fa ruotare la girante utilizzando il campo magnetico.

Protezione IP 44. Isolamento classe F. Temperatura massima del liquido da pompare 80 °C; massima densità 1100 kg/m³; massima viscosità 30 cPs.

 Magnetic drive pumps for transferring acids, corrosive liquids, solvents for photo printing, alkaline liquids, salted water, etc. Pump body and impeller in propylene reinforced with fibre glass. Shaft in ceramic. The impeller contains a magnet. The leading magnet from outside the pump body creates a magnetic field and it gets the impeller to rotate.

Protection class IP 44. Insulation class F. Max. temperature of pumped liquid 176 °F (80 °C); max. density 1100 kg/m³; max viscosity: 30 cPs.

 Pompes à entraînement magnétique pour le pompage de liquides acides et corrosifs, solvants pour l'impression photographique, bases liquides, eau salée, etc.

Corps de pompe et roue en propylène avec fibre de verre. Arbre en céramique. La roue inclue un aimant. Un entraineur magnétique fixé sur l'axe du moteur transmet le mouvement à l'aimant de la turbine.

Protection IP 44. Isolation classe F. Température max. du liquide pompé 80 °C; densité max. 1100 kg/m³; viscosité max: 30 cPs.

 Magnetgetriebene Kreiselpumpen sind in vielen Anwendungen wie bei chemischen Prozessen, Galvanotechnik, Wasseraufbereitung, Photoentwicklung, usw. zu finden.

Pumpengehäuse und Laufrad aus Propylen mit Nirosta. Antriebswelle aus Keramik. Ein Magnetpaar, welches mit dem Laufrad verbunden ist, treibt die Pumpe an. IP 44 Schutz. Isol. Klasse F. Max. Temperatur der Flüssigkeit 80 °C; max. Dichte 1100 kg/m³, max Viskosität: 30 cPs.

Modello Model Modèle Modell	Potenza Power Puissance Pferdestärke		Tensione Voltage Bobinage Spannung	A	Giri/min. R.p.m. Tours/min U./min	Portata - Capacity - Débit - Fördermenge (l/min)					
	HP	W				10	20	30	50	70	90
	Prevalenza - Head - Hauteur - Förderhöhe (m)										
MAG 04	0.04	30	230/50/1	0,1	2800	2,2	1,3				
MAG 08	0.08	60	230/50/1	0,2	2700	3,1	2,5	1,7			
MAG 13	0.13	100	230/50/1	0,6	2850	5,3	5	4,5	2,5		
MAG 20	0.20	150	230/50/1	1,6	2850	7,8	7,5	7,1	6	3,5	
MAG 33	0.33	250	230/50/1	1,8	2850	8,8	8,5	8,1	7	5,6	3,4

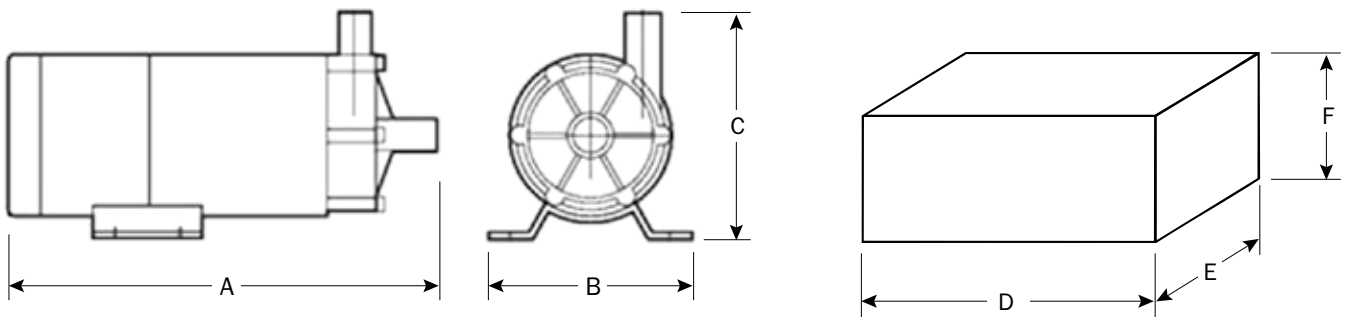
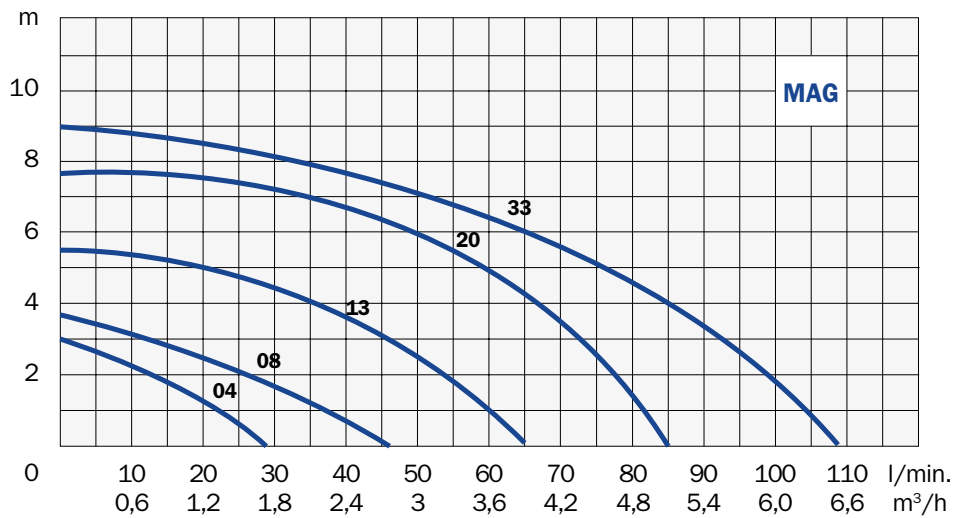

Modello Model Modèle Modell	Aspirazione Suction Aspiration Saug-Seite	Mandata Discharge Refolement Druck-Seite	Dimensioni - Dimensions - Masstabelle						Peso Weight Poids Gewicht
			mm						
			A	B	C	D	E	F	
MAG 04	3/4" - DN 20	3/4" - DN 20	181	92	114	230	110	160	2,2
MAG 08	3/4" - DN 20	3/4" - DN 20	206	120	130	325	205	220	3,0
MAG 13	3/4" - DN 20	3/4" - DN 20	272	95	134	320	210	280	3,5
MAG 20	1" - DN 25	1" - DN 25	286	130	160	320	210	280	7,5
MAG 33	1" - DN 25	1" - DN 25	345	156	175	380	220	210	9,5